

LOGO	REV.	Date	Changes
△			
△			
△			

F

F

E

E

D

D

C

C

B

B

A

A

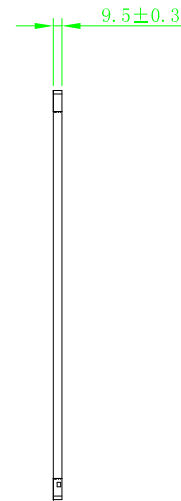
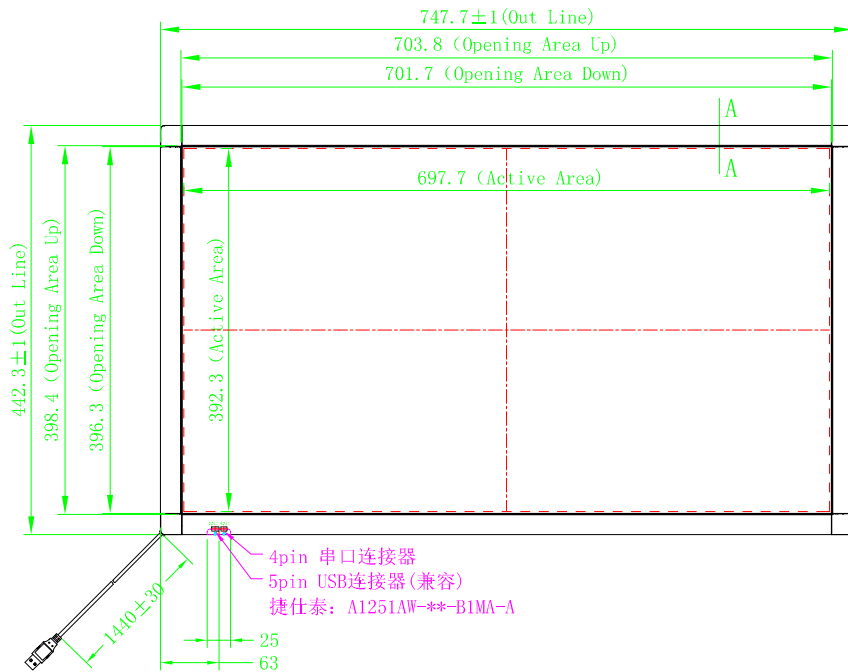

4pin 串口连接器  
5pin USB连接器(兼容)  
捷仕泰: A1251AW-\*\*-B1MA-A

Refer to AUO Display Design

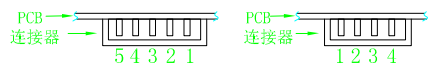

PIN PIN1:VCC  
脚 PIN2:D-  
定 PIN3:D+  
义 PIN4:GND  
PIN5:屏蔽线

PIN PIN1:VCC  
脚 PIN2:TTL-RXD  
定 PIN3:TTL-TXD  
义 PIN4:GND

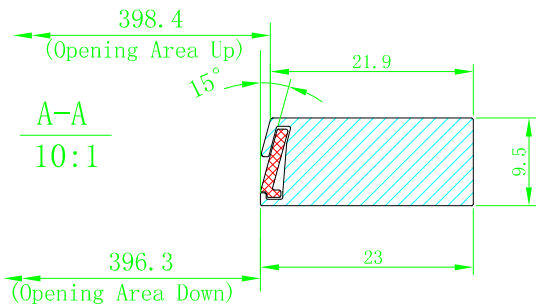

TOLERANCES (UNLESS OTHERWISE STATED)	
DECIMALS	ANGLES ±0.5°
> 2000mm	± 2.00mm
1600 < × ≤ 2000mm	± 1.20mm
1200 < × ≤ 1600mm	± 0.80mm
800 < × ≤ 1200mm	± 0.50mm
400 < × ≤ 800mm	± 0.40mm
120 < × ≤ 400mm	± 0.30mm
30 < × ≤ 120mm	± 0.20mm
≤ 30mm	± 0.10mm

THIRD ANGLE PROJECTION

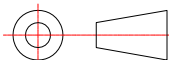

OBEY Co., LIMITED

MODEL NO.		SCALE	1:1	NOTES:
PART No.	<b>F315WH00D</b>	REV.	1.0	
PART NAME	产品尺寸图	SIZE	FREE	
UNIT	mm	SHEET	1/1	
MATERIAL			CHK' D	
SURFACE			APP' D	
DRAWN		2014.05.30 17:03:13 +08'00'		