

8

7

6

5

4

3

2

1

LOGO	REV.	Date	Changes
△			
△			
△			

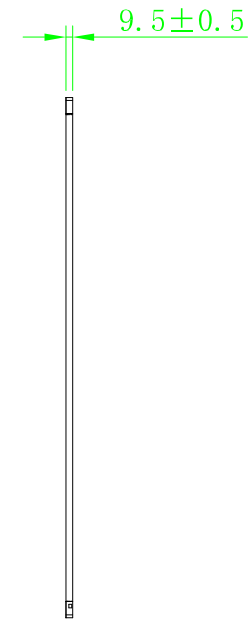
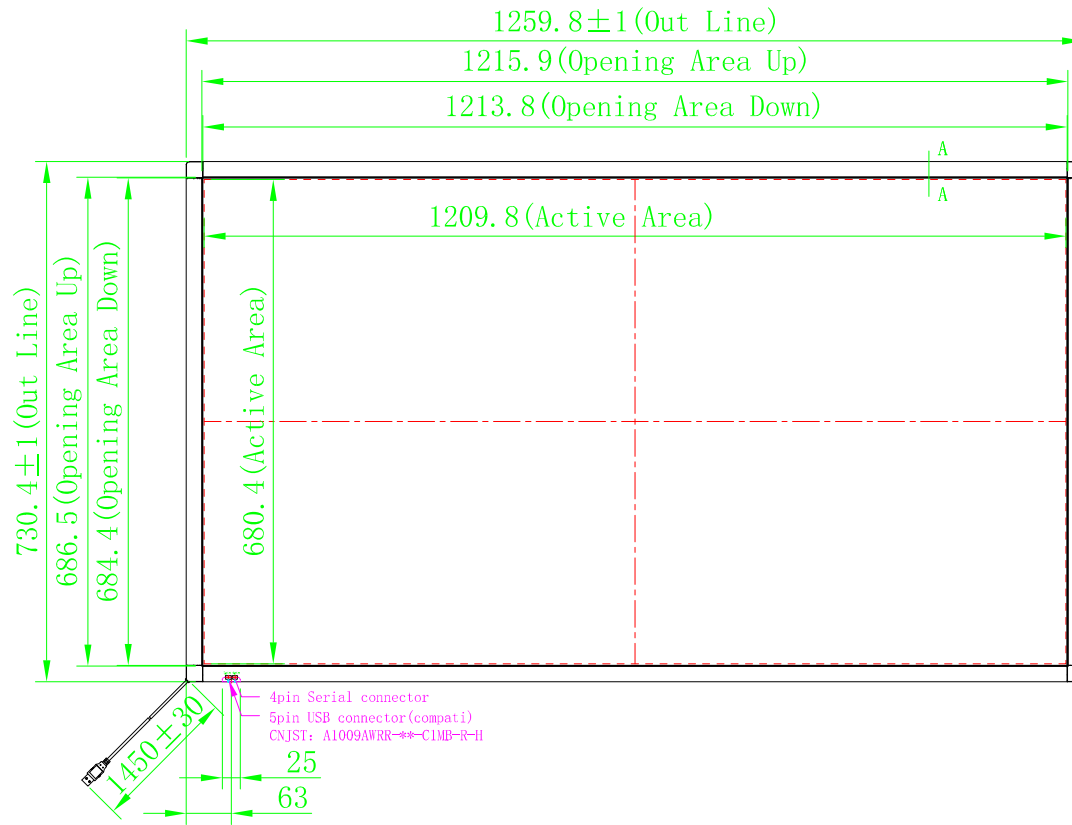

Refer to AU Display

注：未注公差 ± 0.2 mm

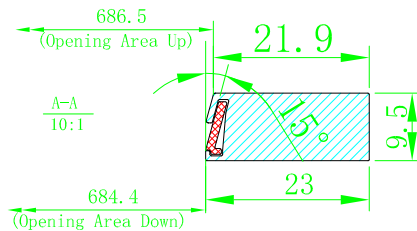

TOLERANCES
(UNLESS OTHERWISE STATED)

DECIMALS	ANGLES	$\pm 0.5^\circ$
$1600 < x \leq 2000$ mm	± 2.00 mm	
$1200 < x \leq 1600$ mm	± 1.20 mm	
$800 < x \leq 1200$ mm	± 0.80 mm	
$400 < x \leq 800$ mm	± 0.50 mm	
$120 < x \leq 400$ mm	± 0.40 mm	
$30 < x \leq 120$ mm	± 0.30 mm	
≤ 30 mm	± 0.20 mm	
	± 0.10 mm	

THIRD ANGLE PROJECTION

OBEY Co., LIMITED

MODEL NO.		SCALE	1:1	NOTES:
PART No.	F55WH00D	REV.	1.0	
PART NAME	产品尺寸图	SIZE	FREE	
UNIT	mm	SHEET	1/1	
MATERIAL		CHK'D		
SURFACE		APP'D		
DRAWN	<i>[Signature]</i>	2016.03.17 10:46:30 +08'00'		

8

7

6

5

4

3

2

1